

**Infinitybox, LLC**

**Addendum to Factory Five 818 Configuration Sheet  
Installation Guide**

**Table of Contents**

Overview ..... 2

Wiring Ignition Input to MASTERCELL..... 3

Wiring Ignition Outputs to POWERCELLS..... 4

Wiring Starter Input to MASTERCELL..... 5

Wiring Starter Outputs to POWERCELL..... 6

Wiring Neutral Safety/Clutch Interlock Input to MASTERCELL..... 7

Wiring Headlight Input to MASTERCELL ..... 8

Wiring Headlight Output to POWERCELL..... 9

Wiring Parking Light Input to MASTERCELL ..... 10

Wiring Parking Light Outputs to POWERCELLS ..... 11

Wiring High-Beam Inputs to MASTERCELL..... 12

Wiring High-Beam Output to POWERCELL ..... 13

Wiring Horn Input to MASTERCELL..... 14

Wiring Horn Output to POWERCELL ..... 15

Wiring Turn-Signal Inputs to MASTERCELL ..... 16

Wiring Hazard (4-Way) Input to MASTERCELL..... 17

Wiring Turn-Signal Outputs to POWERCELLS..... 18

Wiring Brake Pedal Input to MASTERCELL..... 19

Wiring Brake Light Output to Rear POWERCELL..... 21

Wiring Back-Up Light Input to MASTERCELL..... 22

Wiring Back-Up Light Output to POWERCELL..... 23

Wiring Cooling Fan Inputs to MASTERCELL..... 24

Wiring Cooling Fan Outputs to POWERCELL..... 25

Wiring Fuel Pump Main Output to POWERCELL..... 26

Warranty Information..... 27

Contact Information..... 28

## Overview

This document gives more detail to the configuration sheet created specifically for the Factory Five 818 3-Cell Kit. It gives more details on how to connect MASTERCELL switch input wires to the Subaru OEM components and the POWERCELL output wires to the switched functions.

Use this a guideline for wiring your Factory Five Racing 818.

Please contact Infinitybox technical support with additional questions.

## Wiring Ignition Input to MASTERCELL

- MASTERCELL Input: Input 3, White-Blue Wire
- Connection to OEM Switch: IG Terminal on Ignition Switch
- Connect MASTERCELL Ground wire to B Terminal on Ignition Switch
- Only one ground wire is required between the MASTERCELL and the Ignition Switch.

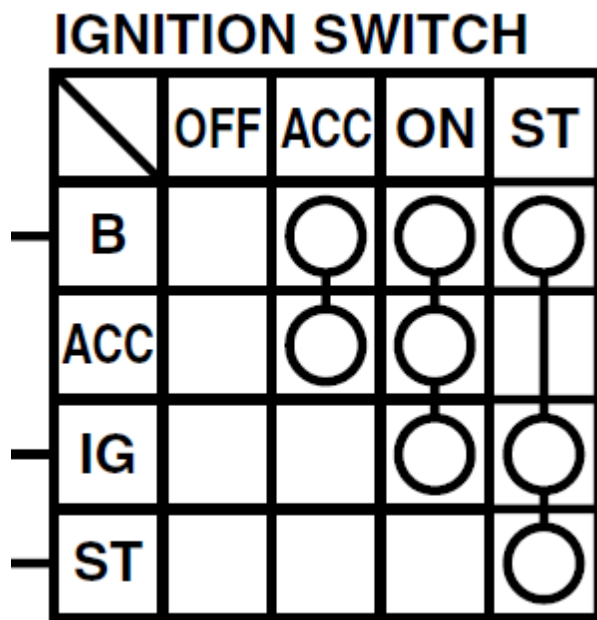

Figure 1: Ignition Switch Details from Subaru Electrical Manual

## Wiring Ignition Outputs to POWERCELLs

- Rear POWERCELL: Output 4, Light-Blue Wire
- Connect to Main Relay and Electronic Throttle Control Relay in ECU harness.
- Recommended Fuse: 20-amp
- Front POWERCELL: Output 10, Tan Wire
- Connect to functions requiring switched ignition power in the front of the car. Use to power wiper control module and gauge cluster.
- Recommended fuse: 20-amp

NOTE: All Ignition outputs will be disabled with security functions from optional inLINK and inTOUCH NET accessories.

NOTE: The fuel pump output on the rear POWERCELL is activated through the ignition switch.

## Wiring Starter Input to MASTERCELL

- MASTERCELL Input: Input 4, White-Yellow Wire
- Connection to OEM Switch: ST Terminal on Ignition Switch
- Connect MASTERCELL Ground wire to B Terminal on Ignition Switch
- Only one ground wire is required between the MASTERCELL and the Ignition Switch.

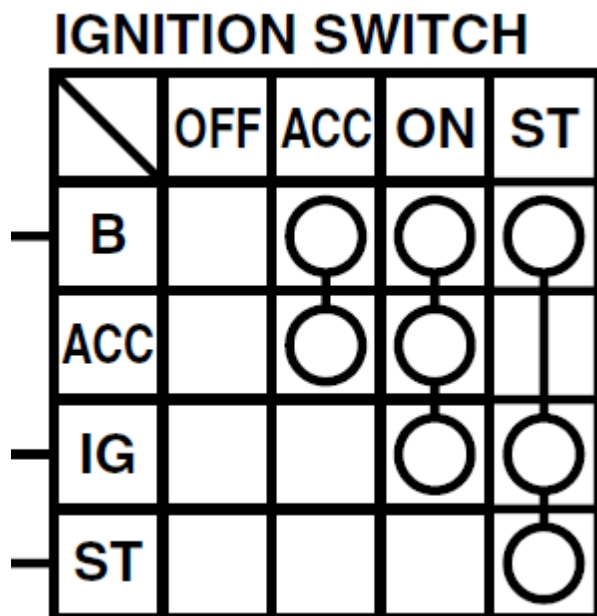

Figure 2: Ignition Switch Details from Subaru Electrical Manual

## Wiring Starter Outputs to POWERCELL

- Rear POWERCELL: Output 5, White Wire
- Connect to starter solenoid terminal on starter motor assembly.
- Recommended Fuse: 20-amp

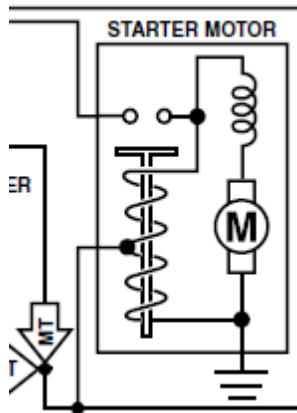

Figure 3: Starter Motor Details from Subaru Electrical Manual

NOTE: The starter output will be disabled with security functions from optional inLINK and inTOUCH NET accessories.

The starter output will not be allowed to engage unless the Neutral Safety/Clutch Interlock MASTERCELL input is grounded.

## **Wiring Neutral Safety/Clutch Interlock Input to MASTERCELL**

- MASTERCELL Input: Input 21, Green-Black Wire
- Switch on transmission must be able to connect MASTERCELL input wire to ground when the transmission is in park/neutral or there must be a switch on the clutch pedal that is able to connect the MASTERCELL to ground when the pedal is depressed.
- MASTERCELL input must for Neutral Safety/Clutch Interlock must be grounded before engaging starter input.
- Opening Neutral Safety/Clutch Interlock input while engine is cranking will turn off power to starter output.

## Wiring Headlight Input to MASTERCELL

- MASTERCELL Input: Input 5, White-Green Wire
- Connection to OEM Switch: HC Terminal on Lighting Switch
- Connect MASTERCELL Ground wire to EC Terminal on Lighting Switch

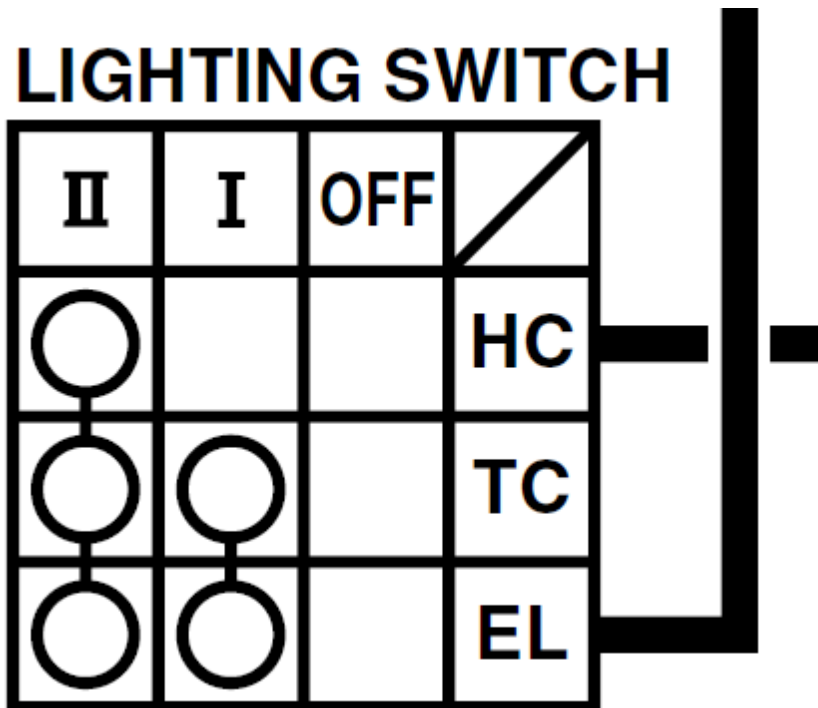

Figure 4: Lighting Switch Details from Subaru Electrical Manual

Note: Standard output for headlight is soft-started. It is to be used for incandescent head lights. If you are using LED or HID bulbs, use MASTERCELL input 23, Green-Blue



## **Wiring Headlight Output to POWERCELL**

- Front POWERCELL: Output 5, White Wire
- Split output to feed both low-beam filaments on left & right side of car. Ground other side of wire to low-beams.
- Recommended Fuse: 20-amp

## Wiring Parking Light Input to MASTERCELL

- MASTERCELL Input: Input 6, Blue-Black Wire
- Connection to OEM Switch: B Terminal on Parking Switch
- Connect MASTERCELL Ground wire to P Terminal on Parking Switch

### PARKING SWITCH

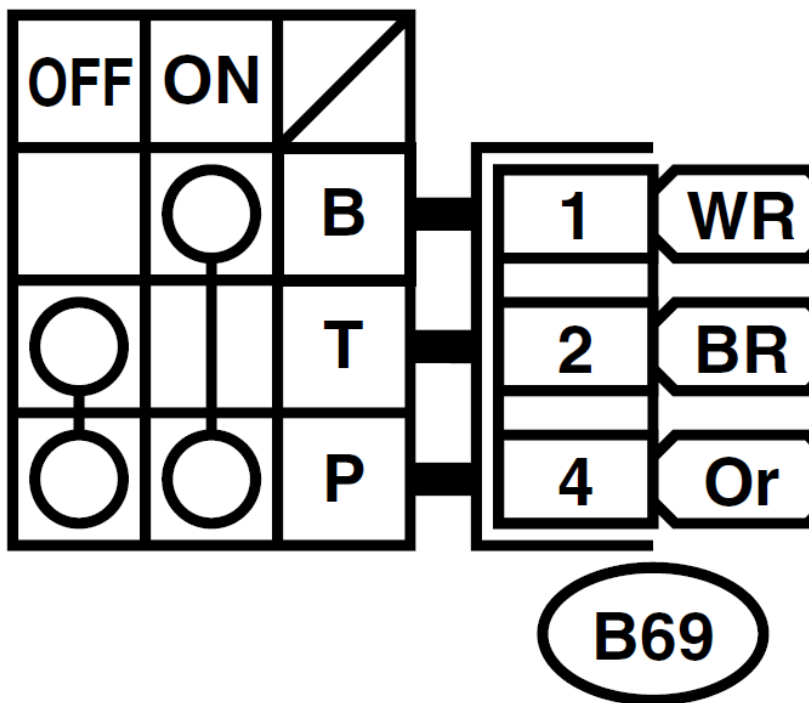

Figure 5: Parking Switch Details from Subaru Electrical Manual

## **Wiring Parking Light Outputs to POWERCELLs**

- Front POWERCELL: Output 6, Yellow Wire
- Connect to both front parking light bulbs and gauge illumination.
  
- Rear POWERCELL: Output 6, Yellow Wire
- Connect to both rear parking light bulbs and license plate light.
  
- Recommended Fuse: 15-amp

## Wiring High-Beam Inputs to MASTERCELL

- High Beam MASTERCELL Input: Input 7, Blue-Red Wire
  - Connect to HU Terminal on Dimmer & Passing Switch
- Flash-to-Pass MASTERCELL Input: Input 22, Green-Red Wire
  - Connect to HF Terminal on Dimmer & Passing Switch
  
- Connect MASTERCELL Ground wire to E Terminal on Dimmer & Passing Switch

## DIMMER & PASSING SWITCH

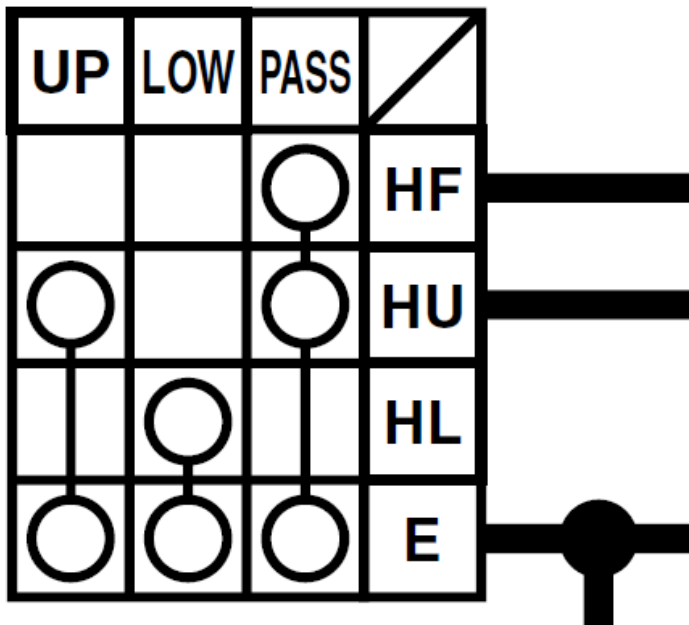

Figure 6: Dimmer & Passing Switch Details from Subaru Electrical Manual

Note: Standard output for high-beams is soft-started. This it to be used for incandescent head lights. If you are using LED or HID bulbs, use MASTERCELL input 24, Green-Orange instead of input 7.

## **Wiring High-Beam Output to POWERCELL**

- Front POWERCELL: Output 7, Blue Wire
- Split output to feed both high-beam filaments on left & right side of car. Ground other side of wire to high-beams.
- Splice off of the POWERCELL output to tap into indicator light for High-Beam indicator in gauge cluster. If using LED for High-Beam indicator, make sure that you have the polarity of the LED properly oriented.
- Recommended Fuse: 20-amp

## Wiring Horn Input to MASTERCELL

- Horn MASTERCELL Input: Input 9, Blue-Yellow Wire
  - Connect to RG wire in steering column.
  - Make sure that column is properly grounded to the chassis.

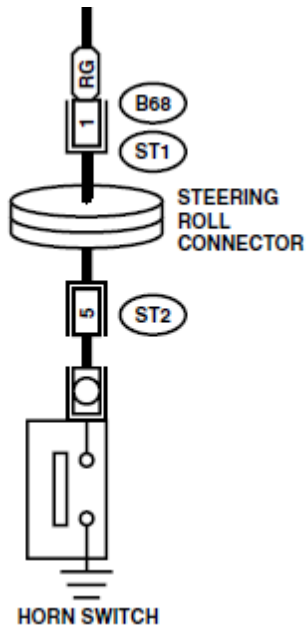

Figure 7: Horn Switch Details from Subaru Electrical Manual

## **Wiring Horn Output to POWERCELL**

- Front POWERCELL: Output 9, Orange Wire
- Connect POWERCELL output wire to one terminal of horn. Ground other terminal to chassis. If multiple horns are used, wire them in parallel.
- Recommended Fuse: 15-amp

## Wiring Turn-Signal Inputs to MASTERCELL

- Left Turn-Signal MASTERCELL Input: Input 11, Yellow-Black Wire
  - Connect to 1 Terminal on Turn-Signal Switch
- Right Turn-Signal MASTERCELL Input: Input 12, Yellow-Red Wire
  - Connect to 3 Terminal on Turn-Signal Switch
- Connect MASTERCELL Ground wire to 2 Terminal on Turn-Signal Switch.

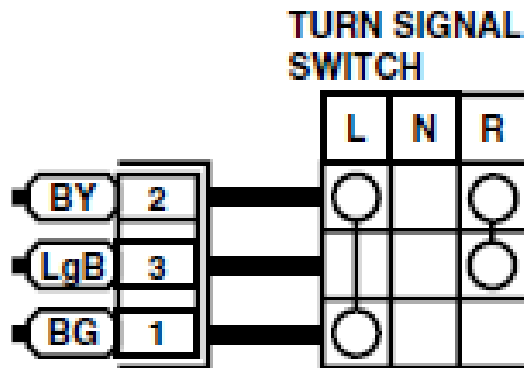

Figure 8: Turn Signal Switch Details from Subaru Electrical Manual

Note: Turn-signals will only operate when the system ignition is on.



## Wiring Hazard (4-Way) Input to MASTERCELL

- 4-Way MASTERCELL Input: Input 13, Yellow-Blue Wire
  - Connect to 8 Terminal on Hazard Switch
- Connect MASTERCELL Ground wire to 7 Terminal on Hazard Switch.

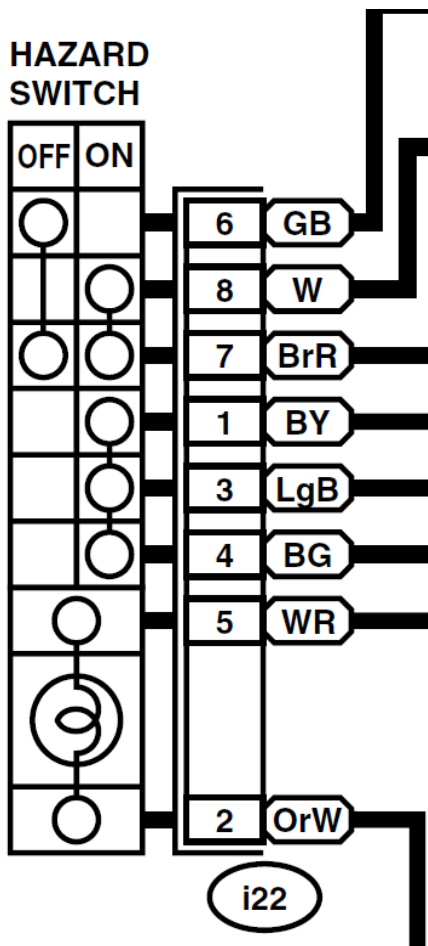

Figure 9: Hazard Switch Details from Subaru Electrical Manual

Note: 4-Way function will operate with the system ignition on or off.

## Wiring Turn-Signal Outputs to POWERCELLs

- Front POWERCELL:
  - Left-Turn Output 1, Brown Wire
  - Right-Turn Output 2, Violet Wire
- Rear POWERCELL:
  - Left-Turn Output 1, Brown Wire
  - Right-Turn Output 2, Violet Wire
- Recommended Fuse: 15-amp for each output.
- Splice off the front outputs for the left & right turn-signals for the indicators in the instrument cluster. If using LEDs for turn-signal indicators, make sure that you have the polarity of the LEDs properly oriented. Also check the maximum forward current for the LED. Some LEDs will require a current limiting resistor to protect them from damage.

NOTE: The system flashes the left & right turn signals in the front & the rear of the car together for the 4-ways. No additional wiring is required for the 4-way outputs.

## Wiring Brake Pedal Input to MASTERCELL

There are two options for your brake light function in the Factory Five 818 Kit.

The first option is what we call “Multi-Filament”. In this option, there is a dedicated output on the rear POWERCELL for the brake lights. As a rule of thumb, you should use this option if your rear turn signals are amber.

The other option is “Single-Filament”. In this option, the output for the turn signals on the rear POWERCELL are used together for the brake lights. As a rule of thumb, you should use this option if your rear turn signals are red.

Follow these instructions for the Multi-Filament option:

- Brake Pedal MASTERCELL Input: Input 15, Yellow-Green Wire
  - Connect to 2 Terminal on Stop Light Switch
- Connect MASTERCELL Ground wire to 3 Terminal on Stop Light Switch.

### STOP LIGHT SWITCH

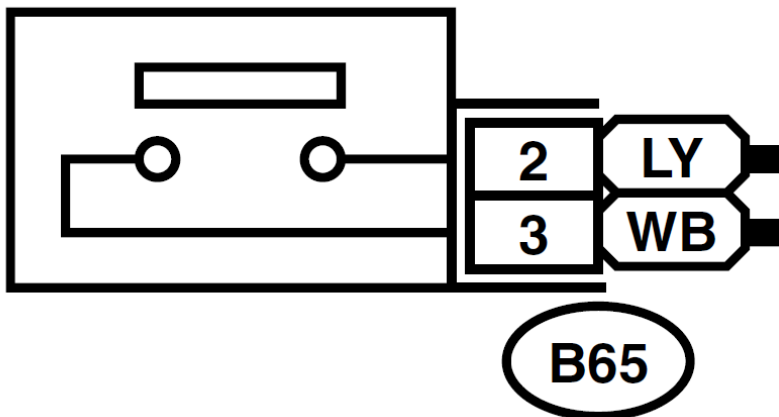

Figure 10: Stop Light Switch Details from Subaru Electrical Manual

Note: Brake Light function will operate with the system ignition on or off.

Follow these instructions for the Single-Filament option:

- Brake Pedal MASTERCELL Input: Input 14, Yellow-Orange Wire
  - Connect to 2 Terminal on Stop Light Switch
- Connect MASTERCELL Ground wire to 3 Terminal on Stop Light Switch.

## STOP LIGHT SWITCH

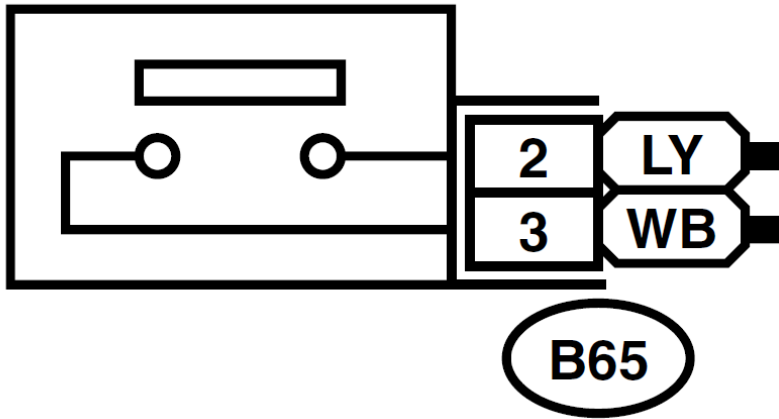

Figure 10: Stop Light Switch Details from Subaru Electrical Manual

Note: Brake Light function will operate with the system ignition on or off.

## **Wiring Brake Light Output to Rear POWERCELL**

**NOTE:** If you are using the Single-Filament brake light option, your rear turn signals also operate as the brake lights. You do not need to do anything else to make them work.

Follow these instructions if you are using the Multi-Filament brake light option.

- Rear POWERCELL:
  - Brake Light Output 3, Light-Green Wire
- Recommended Fuse: 10-amp for each output.

**NOTE:** The brake lights will work when the ignition input is on or off.

## Wiring Back-Up Light Input to MASTERCELL

- Brake Pedal MASTERCELL Input: Input 16, Tan-Black Wire
  - Connect to 1 Terminal on Back-Up Light Switch
- Connect MASTERCELL Ground wire to 2 Terminal on Back-Up Light Switch.

### BACK-UP LIGHT SWITCH (MT)

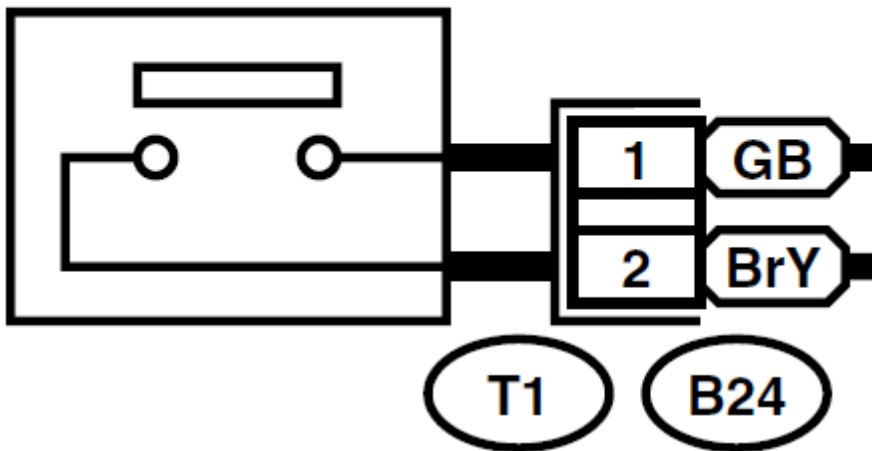

Figure 11: Back-Up Switch Details from Subaru Electrical Manual

Note: Back-Up Light function will only operate with the system ignition on.

## **Wiring Back-Up Light Output to POWERCELL**

- Rear POWERCELL: Output 7, Blue Wire
- Splice the POWERCELL output wire to one lead of both the back-up light bulbs. Ground the other side of the bulbs to the chassis.
- Recommended Fuse: 15-amp

## Wiring Cooling Fan Inputs to MASTERCELL

The Infinitybox system for the 818 is set up to manage two cooling fans via the OEM ECM.

- Main Cooling Fan 1 MASTERCELL Input: Input 1, White-Black Wire
  - Connect to GR wire on Subaru ECM
- Sub Cooling Fan 2 MASTERCELL Input: Input 2, White-Red Wire
  - Connect to RL wire on Subaru ECM

NOTE: Wire a 1N4001 rectifier diode in series between the MASTERCELL input wires and the ECM. The cathode of the diode should face the ECM.

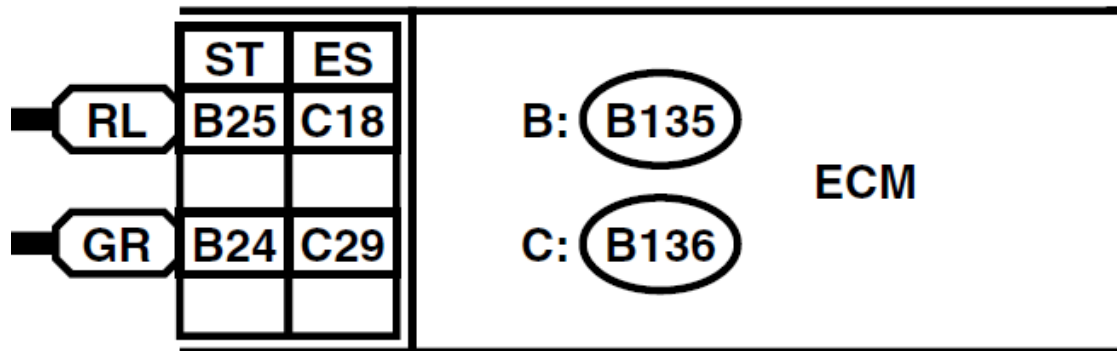

Figure 12: ECM Details for Cooling Fan Triggers from Subaru Electrical Manual

Note: Cooling fans will only operate with the system ignition on.



## **Wiring Cooling Fan Outputs to POWERCELL**

- Main Cooling Fan
  - Front POWERCELL- Output 3, Light-Green Wire
- Sub Cooling Fan
  - Front POWERCELL- Output 4, Light-Blue Wire
- Wire the POWERCELL output to the positive wire on the cooling fan. Ground the negative wire to the chassis.
- Recommended Fuse: 25-amp for each output.

## Wiring Fuel Pump Main Output to POWERCELL

- Rear POWERCELL: Output 10, Tan Wire
- The Fuel Pump output on the rear POWERCELL replaces the fuel-pump relay in the OEM harness.
- Wire the POWERCELL fuel pump output to the incoming power feed to the Subaru Fuel Pump Control Module.
- Recommended Fuse: 20-amp

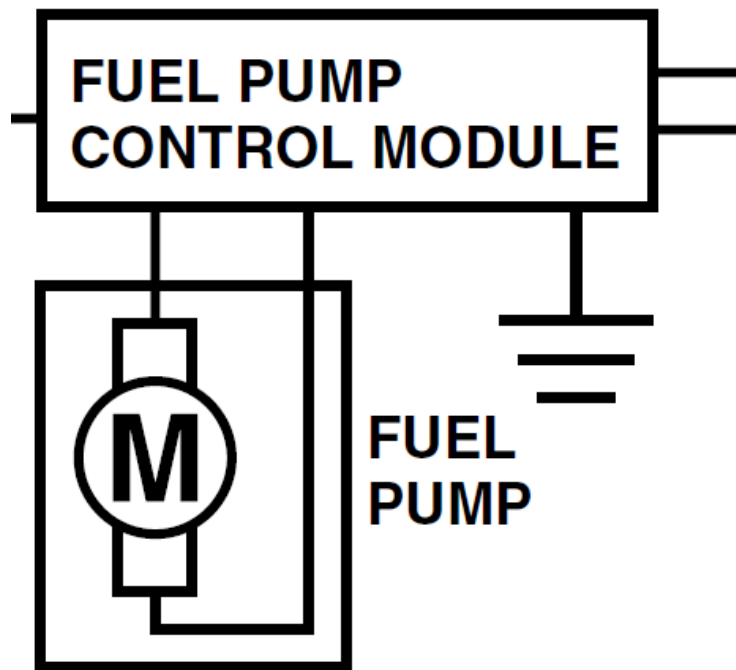

Figure 12: Fuel Pump Control Module Details from Subaru Electrical Manual

## Warranty Information

Infinitybox, LLC (“Infinitybox”) warrants against any defects in materials and workmanship to the Product’s Infinitybox™ modules, wiring harnesses and accessory modules for a period of one (1) year from the first date of purchase. Subject to the terms of this warranty described below, Infinitybox will replace any such defective Product that is returned to Infinitybox within the one (1) year period from initial purchase. Replacement of any defective part or Product will not extend the applicable warranty period.

The warranty does not apply to: (i) any Product that is not installed in compliance with the applicable Product documentation; (ii) any defect in, or failure of, the Product resulting from an accident, shock, negligence, water immersion or misuse; (iii) any Product that has been modified, adjusted, repaired, or disassembled by any party other than Infinitybox; or (iv) any defect other than in materials and workmanship.

This warranty covers only the original purchaser of Product purchased from an Infinitybox authorized dealer in the United States. In order to receive warranty service, purchaser must provide Infinitybox with a copy of the receipt stating the dealer name, product purchased and date of purchase. Products found to be defective during the warranty period will be replaced (with a product deemed to be equivalent or better) at the discretion of Infinitybox.

Infinitybox’s sole liability for any defective Product is limited solely to the replacement of Product pursuant to this warranty. Infinitybox reserves the right to replace any repairable parts with new or refurbished parts.

INFINITYBOX DISCLAIMS ALL OTHER WARRANTIES, WHETHER EXPRESS, IMPLIED OR STATUTORY, SUCH AS WARRANTIES OF MERCHANTABILITY AND FITNESS FOR PURPOSE. IN NO EVENT SHALL INFINITYBOX BE LIABLE FOR ANY PUNITIVE, INDIRECT, INCIDENTAL OR CONSEQUENTIAL DAMAGES, INCLUDING WITHOUT LIMITATION, LIABILITY FOR LOSS OF USE, LOSS OF PROFITS, LOSS OF PRODUCT OR BUSINESS INTERRUPTION HOWEVER THE SAME MAY BE CAUSED, INCLUDING NEGLIGENCE.



INFINITYBOX, LLC  
1410 Brummel Street  
Elk Grove Village, Illinois 60007  
[www.infinitybox.com](http://www.infinitybox.com)

## Contact Information

The Infinitybox System is a product of  
**Infinitybox, LLC**  
**1-847-232-1991**  
**[sales@infinitybox.com](mailto:sales@infinitybox.com)**  
**[www.infinitybox.com](http://www.infinitybox.com)**