

# Infinitybox inMOTION NGX Door Control Module Kit

## Installation Manual

### Table of Contents

Warnings.....	2
Introduction .....	3
inMOTION NGX- J1939 Door Control Module Technical Details .....	4
Contents of inMOTION NGX Kit .....	5
inMOTION NGX Connector & Harness Details .....	6
Installation Steps:.....	8
STEP 1: Mounting the inMOTION NGX Cells.....	10
STEP 2: Running Power and Ground.....	12
STEP 3: Connecting the CAN Cables .....	13
STEP 4: Configuring inMOTION NGX.....	16
STEP 5: Wiring the inMOTION NGX Outputs.....	20
STEP 6: Wiring the Switches.....	22
Warranty Information .....	24
Contact Information .....	25

## Warnings

THE INFINITYBOX INMOTION NGX KIT IS AN ADVANCED ELECTRICAL POWER MODULE. PROPER CARE MUST BE TAKEN TO FUSE THE INPUT FEEDS TO THE MODULE. IMPROPER FUSE SELECTION CAN CAUSE DAMAGE TO THE VEHICLE ELECTRICAL SYSTEM RESULTING IN FIRE.

PROPER CARE MUST BE TAKEN TO ENSURE THAT POWER IS CORRECTLY APPLIED TO THE INMOTION NGX CELLS. REVERSING POLARITY TO THE POWER AND GROUND FEEDS WILL CAUSE IRREPARABLE DAMAGE TO THE CELLS AND WILL VOID THE WARRANTY.

THE INPUTS ON THE INMOTION NGX MODULE ARE INTENDED TO BE GROUND SWITCHED. DO NOT APPLY POSITIVE VOLTAGE TO THESE INPUTS. DOING SO WILL DAMAGE THE INMOTION NGX MODULE AND VOID THE WARRANTY.

USE CAUTION WHEN WELDING ON THE CHASSIS OF YOUR CAR OR TRUCK. IF YOU ARE GOING TO WELD, UNPLUG ALL CONNECTIONS TO ALL OF YOUR INFINITYBOX MODULES. WELDING ON YOUR CHASSIS WITH THE CONNECTORS PLUGGED INTO YOUR MODULES COULD DAMAGE THEM AND VOID YOUR WARRANTY.

ADDING ANY ELECTRONICS MODULES TO A VEHICLE WILL INCREASE THE DEMAND ON THE BATTERY. CARE MUST BE TAKEN TO MAINTAIN A CHARGE ON THE BATTERY WHEN THE VEHICLE SITS IDLE FOR PERIODS OF TIME. DEPENDING ON THE TYPE OF BATTERIES AND THE TOTAL AMOUNT OF ELECTRONICS INSTALLED IN THE CAR, THIS IDLE TIME COULD RANGE FROM MONTHS DOWN TO DAYS BEFORE THE BATTERY IS DRAINED TO THE POINT WHERE YOU CANNOT START THE ENGINE. WE STRONGLY RECOMMEND INSTALLING A DISCONNECT SWITCH THAT SEPARATES THE ELECTRICAL LOADS IN THE VEHICLE FROM THE BATTERY WHEN NOT IN USE.

## Introduction

The Infinitybox inMOTION NGX Door Control Module is a unique product in the restoration & performance market. It offers 2 h-bridge relays, 4-outputs and 8-inputs in a rugged and compact module. It is intended to be mounted in a door to provide local control of power locks, power windows and low-current indicator lights. It has 8 inputs to provide local control plus to send J1939 messages to other devices on the Infinitybox network. This can dramatically simplify the wiring in your doors. The only wiring required to go to the door is power, ground and the two CAN data wires. This also has broad applications in custom vehicles where reversing and polarity control are needed.

You can easily scale the number of inMOTION NGX modules that you need in your car or truck project. You can easily add two or 4 inMOTION NGX modules depending on the number of doors you have.

The Infinitybox system gives you complete flexibility for how you control your power windows and power locks. You can control these locally from the inputs wired to switches in your door. You can also control your doors and locks from switches wired to your MASTERCELL NGX that is part of your Infinitybox IPM1 kit. You also can control your doors from our inLINK key fobs or a smart phone with our inLINK NGX module.

**Please note that the Infinitybox inMOTION NGX module is only compatible with the Next Generation IPM1 Kit including the MASTERCELL NGX and POWERCELL NGX. This is not compatible with legacy Infinitybox 3-Cell or 20-Circuit Kits.**

## inMOTION NGX- J1939 Door Control Module Technical Details

- Number of Outputs:
  - Two H-Bridge Pairs for Polarity Control
  - Four High-Side Switched MOSFET Outputs
- Current Carrying Capability
  - H-Bridge Pairs
    - 15-Amp intermittent use (10% duty cycle)
    - 7.5-Amp continuous
  - MOSFET Outputs
    - 1-Amp each, 4-Amps total
- Inputs:
  - 8 ground switched inputs
- Electrical Parameters:
  - Input Voltage: 10 to 18 VDC
  - Steady-State Current Draw: 20 mA nominal
  - Incoming power protected against Load Dump per ISO16750-2
  - All outputs are suppressed to properly switch inductive loads
- Active Current Monitoring:
  - The current level for all outputs is continuously broadcast
  - Resolution is 0.125 Amps
  - Current levels are broadcast every 500 ms.
- Physical Details:
  - 119 mm X 133 mm X 36 mm
  - Housing sealed to IP67
  - Connectors are sealed Deutsch / TE Connectors
  - All plastics are UL94V0
  - Drawings and 3D models are available upon request

## Contents of inMOTION NGX Kit

<b>Component</b>	<b>Quantity</b>	<b>Part Number</b>
J1939 inMOTION NGX Module	1	852-086A8
inMOTION NGX Power & Output Harness	1	858-501
inMOTION NGX CAN & Input Harness	1	858-502
4-Position ATO Holder	1	904-001
15-AMP ATO Fuse	2	904-420
14-16 AWG ¼" Ring Terminal	4	913-019

## inMOTION NGX Connector & Harness Details

The inMOTION NGX module has two sealed Deutsch/TE connectors and harnesses. These wires connect the inMOTION NGX to the rest of your Infinitybox J1939 network. They bring power and ground to the module plus connect the switches and outputs. The following picture identifies these two connectors on the inMOTION NGX module. To build your own harnesses or to repair existing harnesses, the part numbers for the connectors, terminals and wedge locks are also shown.

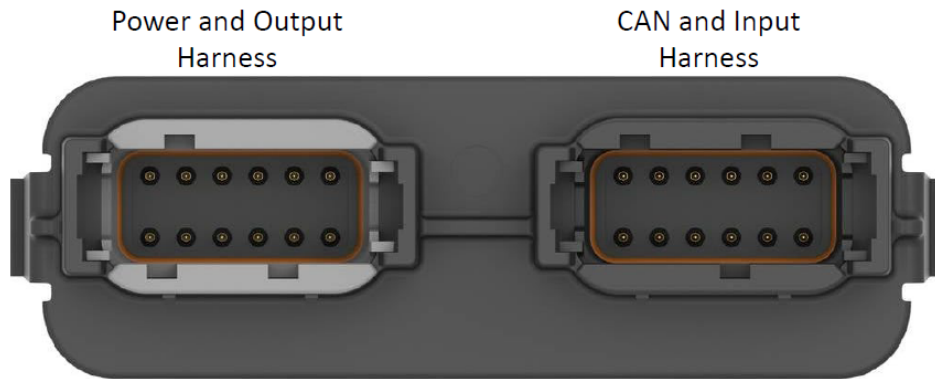

- **Power & Output Harness**
  - Connector: DTM06-12SA
  - Wedglock: WM-12S
  - Terminal: 1062-20-0622
- **CAN & Input Harness**
  - Connector: DTM06-12SB
  - Wedglock: WM-12S
  - Terminal: 1062-20-0222

These two harnesses are identified by the color of the connector and the socket on the module. The Power and Output harness connector and socket are grey. The CAN and Input harness connector and socket are black. These connectors are keyed so that they cannot be plugged in incorrectly.

To install the connectors into the sockets, align the keying features on the connector with their respective features on the socket. Push the connector into the socket until you hear an audible click. To remove the connector from the socket, squeeze on the locking tabs located on the narrow sides of the connector and pull out. Pull from the connector. Do not pull on the wires to remove the connector from the socket.

The following table shows the cavity ID, the wire color and the function for each of the wires in the Power and Output harness. The Infinitybox part number for this harness is 858-501.

Cavity ID	Function	Wire Color	Wire Gauge
1	Relay 2A Output	Yellow	14-AWG
2	Relay 1A Output	White	14-AWG
3	Output 3	Light Green	14-AWG
4	Output 1	Brown	14-AWG
5	Chassis Ground	Black	14-AWG
6	Chassis Ground	Black	14-AWG
7	+ Battery Voltage	Red	14-AWG
8	+ Battery Voltage	Red	14-AWG
9	Output 2	Violet	14-AWG
10	Output 4	Light Blue	14-AWG
11	Relay 1B	Grey	14-AWG
12	Relay 2B	Orange	14-AWG

The following table shows the cavity ID, the wire color and the function for each of the wires in the CAN and Input harness. The Infinitybox part number for this harness is 858-502.

Cavity ID	Function	Wire Color	Wire Gauge
1	CAN LO	Green	22-AWG
2	CAN HI	Yellow	22-AWG
3	Input 2	White-Red	22-AWG
4	Input 4	White-Yellow	22-AWG
5	Input 6	Blue-Black	22-AWG
6	Input 8	Blue-Grey	22-AWG
7	Input 7	Blue-Red	22-AWG
8	Input 5	White-Green	22-AWG
9	Input 3	White-Blue	22-AWG
10	Input 1	White-Black	22-AWG
11	Ground (Reference for Switches)	Black	22-AWG
12	Ground (Reference for Switches)	Black	22-AWG

## Installation Steps:

### **\*\*\*STOP & READ CAREFULLY!\*\*\***

You are about to wire your car with the next generation Infinitybox system. There is no system on the market that can give you the power and flexibility that you can get with Infinitybox. There are a few things you need to consider as you go through this process.

- Read the Instructions
  - We've been evolving these instructions since we started our business in 2008. We have learned from our customers' questions. These lessons are summarized here. We are always adding more information to our website. Check it out at [www.infinitybox.com](http://www.infinitybox.com).
- Find your Configuration Sheet
  - Your kit includes a printed copy of your configuration sheet. This is your roadmap to wiring the car. It will identify which input wires connect to your switches and which output wires connect to your loads. We have several different configurations and yours will be specific to your kit. The wire colors for your inMOTION NGX harnesses are defined on the configuration sheet that came with your IPM1 Kit. Contact our technical support team if you need help finding this.
- Safety
  - The electrical wiring system controls everything in your car. It is what really makes it go. Fuel delivery, starting the engine, managing the ignition, keeping things cool, safety, audio and entertainment all need reliable electrical power to work correctly. Follow our instructions carefully.
- Use the Right Tools
  - Stay away from the hardware store and sketchy sellers on Amazon when buying tools or supplies to wire your car. Give our technical support team a call if you need help getting what you need to do the job correctly.
- Ask Questions
  - Wiring is a daunting process for anyone. The worst thing that you can do as you go through the process is not ask a question, no matter how basic it may seem. We have a great team of tech guys that can help with any question.

- Read the Instructions
  - Did we mention that you should read the instructions? There is also a wealth of specific wiring examples in the Resources section of our website at [www.infinitybox.com](http://www.infinitybox.com).

Each section of this manual will have detailed instructions on what you need to do. There will be a checklist that you should complete at the end of each section. Please use this as a tool to help make your installation simple and efficient.

### STEP 1: Mounting the inMOTION NGX Cells

The inMOTION NGX modules are designed to be mounted directly in the door of your car or truck. The module has polarity reversing outputs for your power locks and power windows plus 4 outputs to power other features like switch illumination, accent lighting, puddle lights and turn signal indicators. All the output wires and the switch wires are connected directly to the inMOTION NGX module inside the door. The only wires passing through the door hinge are power, ground and the two-wire J1939 CAN connection.

There are 4 primary versions of the inMOTION NGX and they are identified by their intended location in the car. If you have a 2-door vehicle, you will be only using inMOTION NGX modules identified as front. If you have a 4-door vehicle, you will have inMOTION NGX modules identified as front & back. Each of these cells is programmed uniquely and must be located in its intended position. The label on the inMOTION NGX module indicates how it is programmed. The following table summarizes the module names and the address. The address is a number used for more advanced programming of your Infinitybox system.

<b>inMOTION NGX Name</b>	<b>Location in Vehicle</b>	<b>CAN Address</b>
Driver Front	Driver Front Door	3
Passenger Front	Passenger Front Door	4
Driver Rear	Driver Rear Door	5
Passenger Rear	Passenger Rear Door	6

inMOTION NGX modules can be custom configured for other applications outside of door functions. These could include linear actuators for trunks, hoods, tonneau covers, tailgates, convertible tops and other polarity control functions. Contact Infinitybox technical support for more details.

The inMOTION NGX housing is completely sealed against water, salt-spray and other road debris. You can mount the module anywhere in the door where it fits. We have also tested the module extensively against vibration and mechanical shock. It is designed to survive tens of thousands of door slams over its lifetime.

Use the two mounting holes in the inMOTION NGX housing to secure the module in the door. The module can be mounted in any orientation. The following picture shows the dimensions of the module millimeters. CAD models of the module are available upon request. Contact Infinitybox technical support for more details.

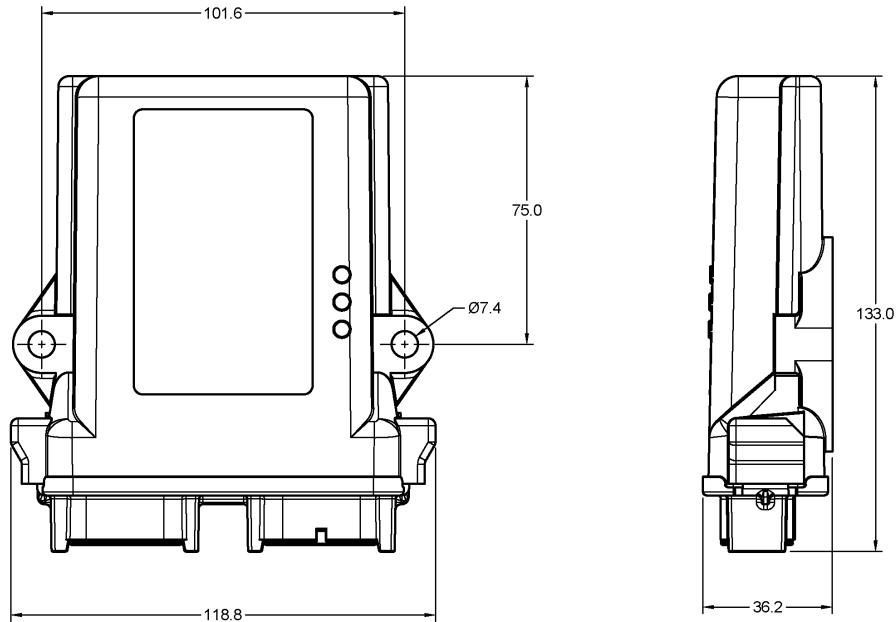

Checklist for Step 1- Mounting the inMOTION NGX Cells

Do you have the inMOTION NGX module securely installed in your door using the mounting holes on the housing?

Did you mount your inMOTION NGX modules in the correct locations based on the label on the housing? **(ONLY APPLICABLE FOR inMOTION NGX MODULES SHIPPED PRIOR TO APRIL 1st, 2026)**

## STEP 2: Running Power and Ground

The inMOTION NGX modules need to get power from your battery. They also need to be grounded to the chassis. The Power and Output harness that comes with the kit includes these wires.

There are two red 14-AWG wires to provide battery power to the module. These power wires need to be fused as close to their connection to the battery as possible. Use the included fuse holder and ring terminals to make the connections to these wires. Do not use fuses with ratings higher than 15-amps to protect the power feeds to the inMOTION NGX module.

There are also two black 14-AWG wires that must be connected to ground for the inMOTION NGX module to operate correctly. We do not recommend grounding these wires inside the door. These should be brought through the hinge and grounded to the vehicle chassis. You must have a clean, metal-to-metal ground connection on the chassis that is free of paint, powder coating, rust, dirt, grease and oil. Please note that these two ground wires are in the Power and Output harness. There are two 22-AWG black wires in the CAN and Input harness that will be discussed separately in Step 6.

Make sure the power and ground wires are properly run from the door to the body of the car. These should be in a channel that allows the wires to properly flex as the door opens and closes. Also make sure that there is no way that these wires could get pinched or crushed when the door closes.

### Checklist for Step 2- Running Power and Ground

Did you properly fuse both red 14-AWG power feeds to the inMOTION NGX module?

Are you using fuses rated at 15-amps, no higher?

Do you have the black 14-AWG wires properly grounded to the chassis with a good metal-to-metal connection?

Can your door open and close safely without pinching or crushing the power and ground wires?

## STEP 3: Connecting the CAN Cables

The Infinitybox Next Generation System communicates using CAN, which stands for Controller Area Network. The specific CAN protocol that we use is called J1939. This is a two-wire, differential pair system commonly used in commercial trucks. Commands are sent between the modules in the Infinitybox system using two wires: CAN LO and CAN HI. These are the green and yellow wires in the CAN and Input harness that plugs into the inMOTION NGX module. These wires correspond to the green and yellow wires in the CAN cable that comes with your Infinitybox IPM1 kit.

The CAN LO and CAN HI wires from the inMOTION NGX modules need to be connected to their corresponding colors in the IPM1 CAN cable and to the CAN wires connected to the other inMOTION NGX modules. We recommend splicing these wires together in-line to the CAN cable. Be sure to properly protect these splices with heat shrink tubing. Please note that we do not recommend using IDC (insulation displacement connectors) to make these connections. Contact Infinitybox technical support with questions about how to make these splices.

The CAN wires should be run from the inMOTION NGX module in the door through a flexible junction that will protect the wires as the door opens and closes. As you are routing your CAN cables through your vehicle, keep these wires away from the high-voltage coil wires of your ignition system.

The following picture shows how to connect the green CAN LO wires and the yellow CAN HI wires from the inMOTION NGX harness to the Infinitybox IPM1 CAN cables. Note that this picture shows inMOTION NGX modules for 4 doors. Your kit could include two or four modules.

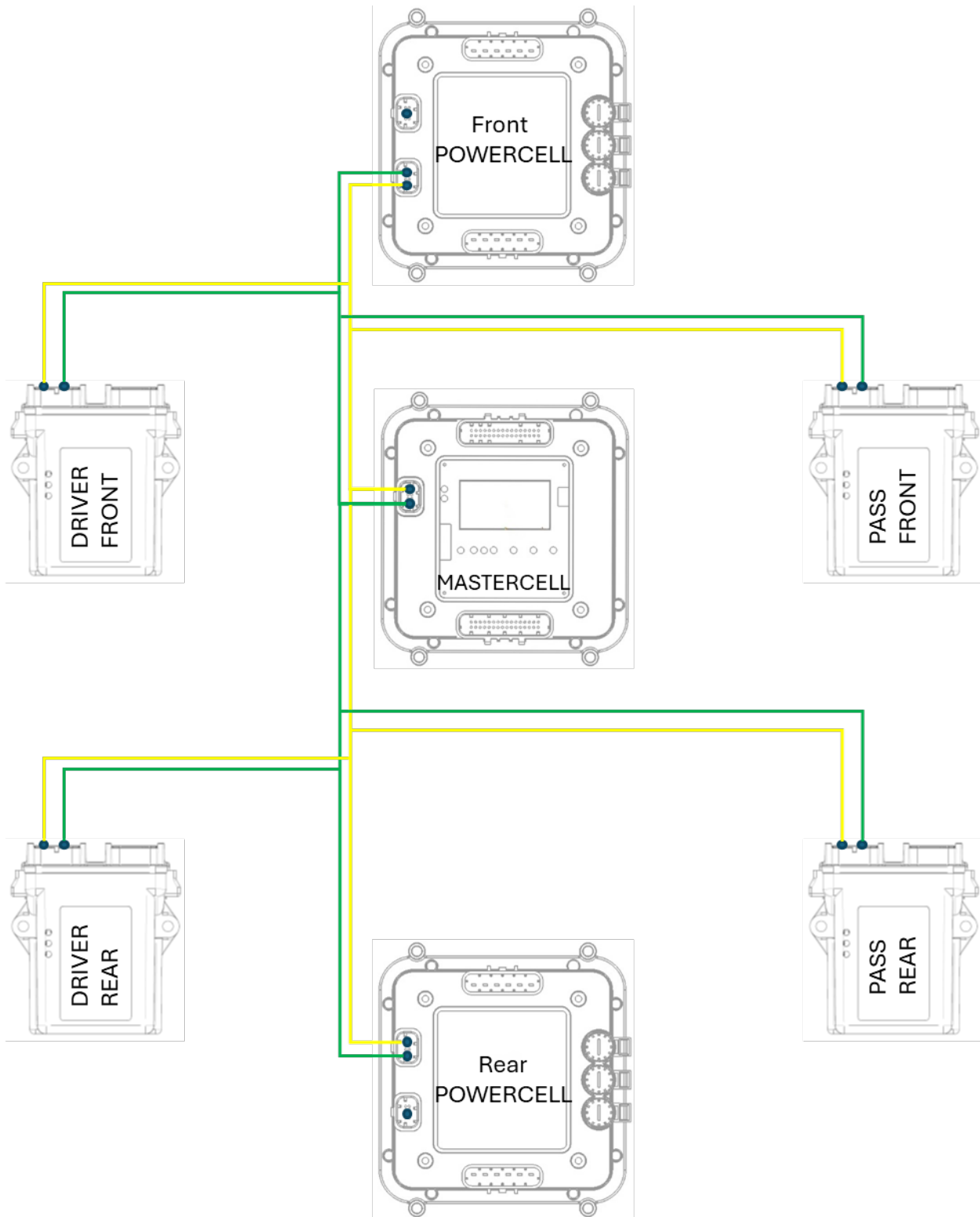

### Checklist for Step 3- Connecting the CAN cables

Is your CAN cable routed away from high-voltage ignition coil wires?

Did you properly splice the green and yellow CAN wires together to the CAN cables connected to the other modules in your Infinitybox network?

Did you properly protect the splices in your CAN cables?

Can your door open and close safely without pinching or crushing the CAN wires?

Did you install the CAN Terminator Resistor into the POWERCELL furthest from your MASTERCELL on the CAN cable?

## STEP 4: Configuring inMOTION NGX

inMOTION NGX modules purchased **BEFORE** April 1st, 2026 come preconfigured. You may skip this step. For modules purchased **AFTER** April 1st, 2026 you must follow this step. The MASTERCELL software revision will be 1.4 or higher for this feature.

Each inMOTION NGX must be assigned to one of four positions:

inMOTION NGX Name	Location in Vehicle	CAN Address
Driver Front	Driver Front Door	3
Passenger Front	Passenger Front Door	4
Driver Rear	Driver Rear Door	5
Passenger Rear	Passenger Rear Door	6

By default, all inMOTION NGX devices are shipped configured as **Driver Front**.

**STEP 1.** Ensure only **one** inMOTION NGX is connected to the CAN network. Disconnect all other inMOTION modules.

**STEP 2.** From the MASTERCELL menu, select inMOTION.

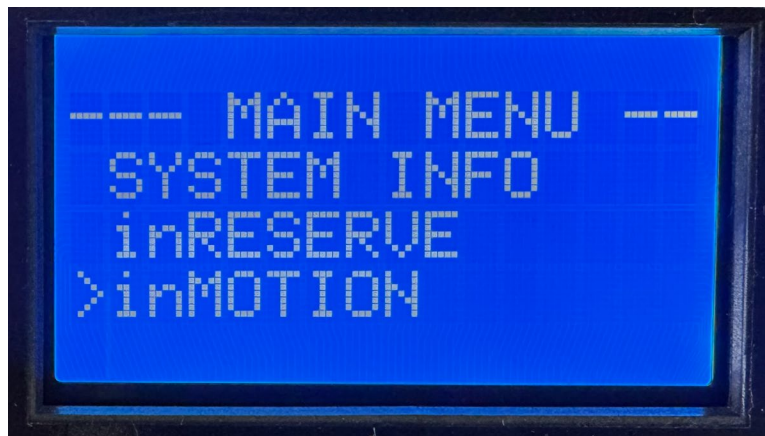

**STEP 3.** The screen displays a connection check:

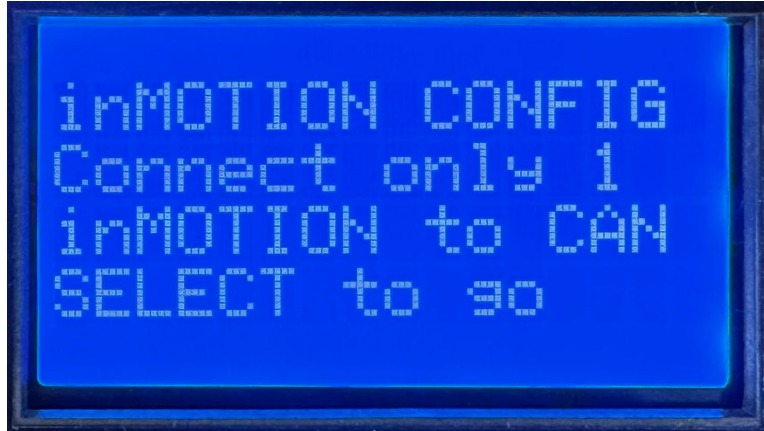

**STEP 4.** When the MASTERCELL detects exactly one inMOTION, “*SELECT to go*” appears on line. Press **SELECT** to proceed.

If no modules are detected, “*Waiting...*” is displayed. Verify the inMOTION has power and is connected to the CAN network.

If more than one inMOTION is detected, the screen displays how many were found and blocks you from proceeding. Disconnect the extra units before continuing.

**STEP 5.** Use **UP/DOWN** to select the desired position (Front Driver, Front Passenger, Rear Driver or Rear Passenger). Press **SELECT** to confirm.

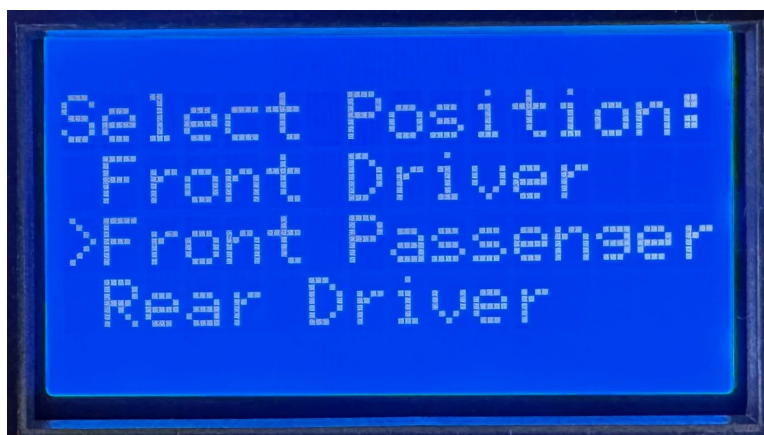

**STEP 6.** A confirmation screen appears. Press **HOME** to cancel and return to the position list.

The MASTERCELL sends the configuration commands over CAN and verifies the inMOTION responds at its new location. This takes a few seconds.

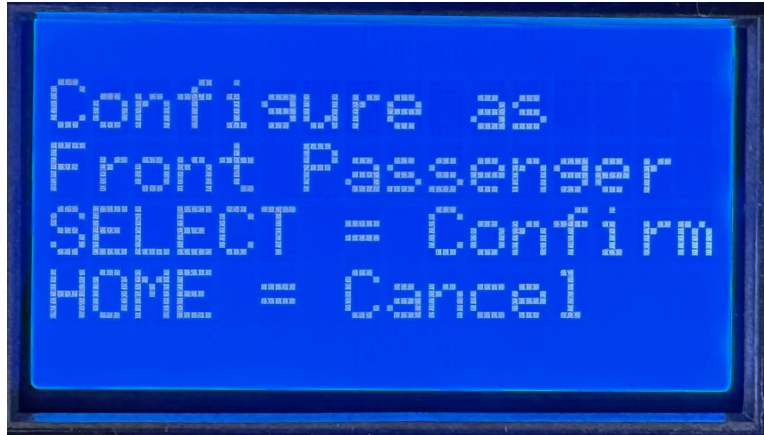

**STEP 7.** On success, the screen displays the new position assignment. Press **HOME** to return to the menu.

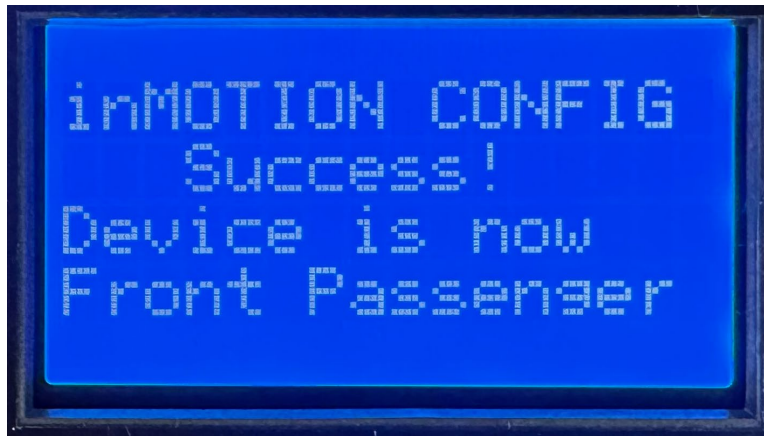

**Step 8.** Repeat this procedure for each inMOTION NGX in the system, connecting them one at a time.

Checklist for STEP 4: Configuring inMOTION NGX

Do you see every inMOTION NGX in your system in System Inventory on the MASTERCELL?

## STEP 5: Wiring the inMOTION NGX Outputs

The inMOTION NGX module has two types of outputs: polarity reversing outputs and outputs to turn loads on and off.

Power lock actuators work by pushing the lock mechanism in the door forward and backward. Power window regulators work by spinning a motor forward or backward to control the up and down motion. In both cases, the current flowing to the actuator or motor needs to change its polarity to change direction. In traditional automotive wiring, the polarity is controlled within the switch. With the Infinitybox inMOTION NGX, we built this polarity control into the module. This lets you control these functions easily with any switch. We use two special polarity reversing relays called an H-Bridge inside inMOTION NGX to control power locks and windows.

Your inMOTION NGX kit came with a configuration sheet that identifies the wires in the Power and Output harness. You are going to connect these output wires to the wires on your power lock actuator and your power window motor.

Please note that the inMOTION NGX module is intended to be used to power 2-wire, DC motors for your lock actuators and power window regulators. Check the wiring diagram that came with your power locks or window kit to make sure that the motors only require 2 wires to properly power them. Contact Infinitybox technical support if there is a ground wire on the motor or if the motor is center tapped.

The following picture shows typical wiring for a power window motor or a power lock actuator.

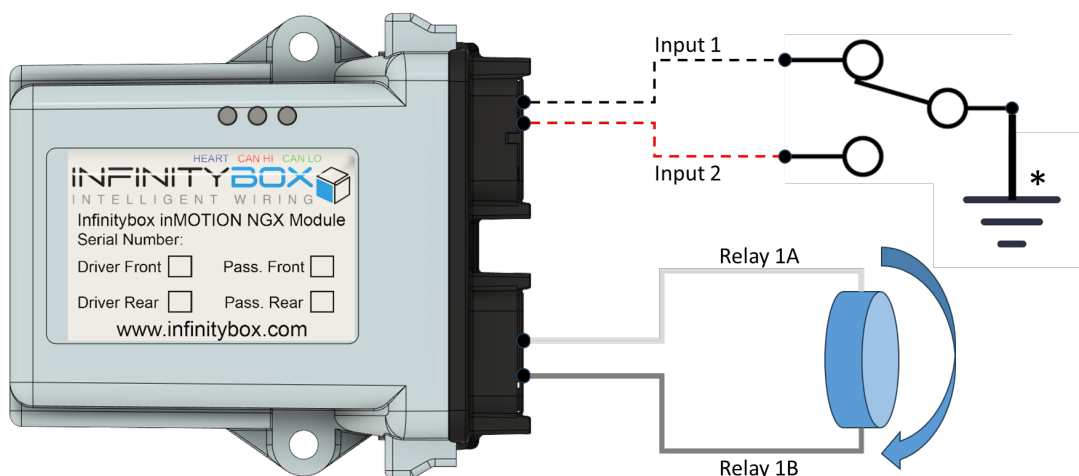

We will discuss the switch wiring in more detail in Step 6.

If you are using door poppers instead of power lock actuators, you can use the lock output to drive the solenoid. Contact Infinitybox technical support for more details on using door poppers.

The inMOTION NGX also has standard outputs that can be used for turning low-current outputs on and off. These outputs can be used to control indicator lights on switches, interior lighting, accent lights, puddle lights and other low-current loads. These outputs are limited to 1-amp per output and are current limited within the module. The following picture shows typical wiring for a standard output on the inMOTION NGX module.

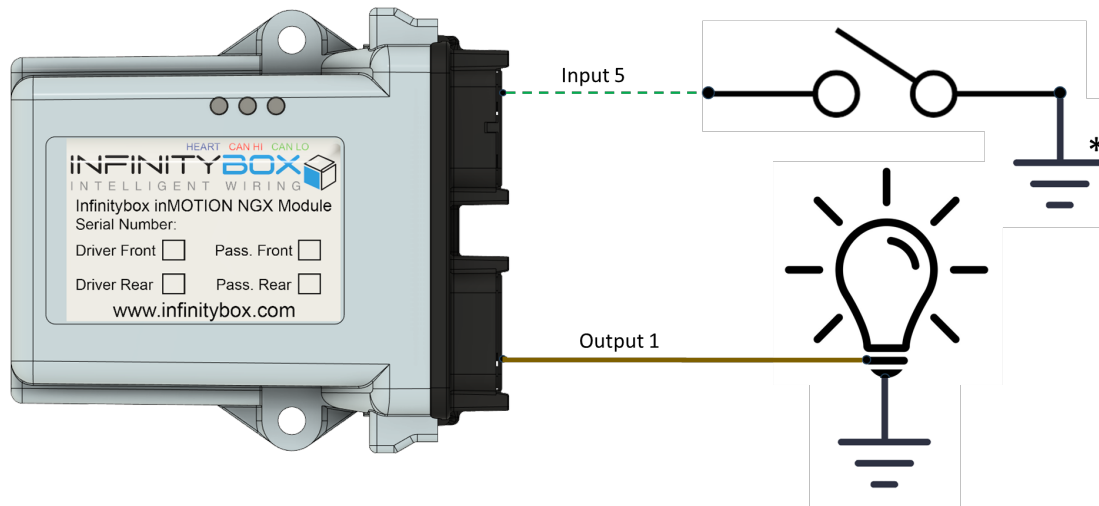

We will discuss the switch wiring in more detail in Step 6.

### Checklist for STEP 5: Wiring the inMOTION NGX Outputs

Did you check the wiring diagrams for your power window motors and power lock actuators to confirm that they are 2-wire DC motors?

Did you make good, clean and reliable connections between the inMOTION NGX output wires and the wires on your actuators, window motors and other loads?

### STEP 6: Wiring the Switches

There are 8 wired inputs going into each inMOTION NGX module. They control the local outputs on inMOTION NGX and outputs on other inMOTION NGX modules. Check your configuration sheet for details on how these inputs control outputs.

The inMOTION NGX inputs are ground switched. That means they turn on when they are connected to ground. This makes connecting the inputs to switches very easy. You simply connect one terminal of your switch to the inMOTION NGX input and you connect the other switch terminal to ground. When the switch is off, the inMOTION NGX input is isolated from ground. When you turn the switch on, the switch connects the input to ground, which triggers the inMOTION NGX module to turn the output on. The following picture shows a diagram of how to connect a simple switch to an inMOTION NGX input.

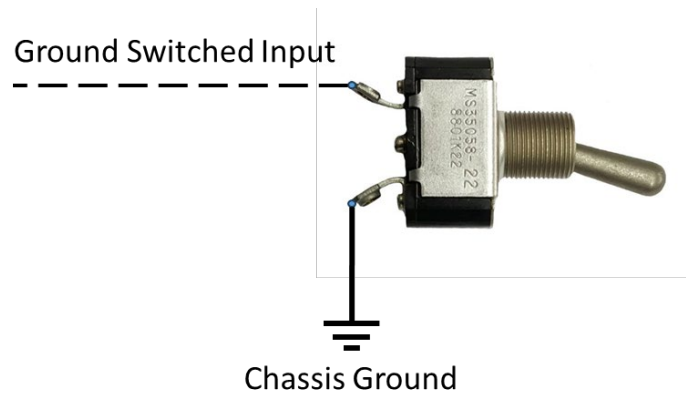

It is very important that you are only connecting ground to the inMOTION NGX inputs. Do not connect positive voltage to the inputs. This will damage the inMOTION NGX module and void the warranty.

There are two 22-AWG black wires in the inMOTION NGX CAN and Input harness. These wires can be used as ground connections for your switches. Do not use these two black wires as ground connections for any loads connected to the inMOTION NGX module. You can also use the metal frame of the door as a ground reference for your switches. If you do this, we highly recommend that you run a separate ground wire from the frame of the door through the hinge and connect it back to the chassis. Simple examples of connecting switches to the inMOTION NGX inputs can be found in the diagrams in Step 5 above.

You can connect practically any switch to the inMOTION NGX inputs. As discussed above, if your switch has two terminals, connect one terminal to the input wire and the other to ground. Some power window switches may seem complicated because they have many more terminals than two. There is a very easy way to determine which terminals to connect to the inMOTION NGX outputs. Look at the wiring diagram that came from the supplier. The terminal that connected to battery positive will be grounded with the inMOTION NGX. The two output

terminals for window up and window down will connect to their respective input wires going to the inMOTION NGX.

You can also verify that you are using the correct terminals with a multimeter. Set your meter to measure resistance. On most meters this is represented by the Greek letter Omega ( $\Omega$ ). If your meter does not auto range, set your meter to the lowest resistance range available. This is typically 20 Ohms. Connect the black lead of your multimeter to what will be the ground terminal on the switch. Connect the red lead of your meter to the terminal that will connect to your inMOTION NGX input. When the switch is off, the meter should read a very high resistance, typically megaohms or M  $\Omega$ . The meter may also read “OL” for overload, meaning that the measured resistance value is out of range. Check the manual that came with your meter for details on high resistance readings.

If you have the red lead connected to the Window Up terminal on the switch and you press the switch in the Window Up direction, you should see the resistance on the meter drop low. Typically, this should measure in the range of less than 10 ohms. Repeat this for the Window Down terminal.

The following diagram shows an example of wiring the inMOTION NGX inputs to the Electric-Life 4980-10-269 power window switches. Wiring diagrams for other popular power window and power lock switches can be found in the reference section at [www.infinitybox.com](http://www.infinitybox.com).

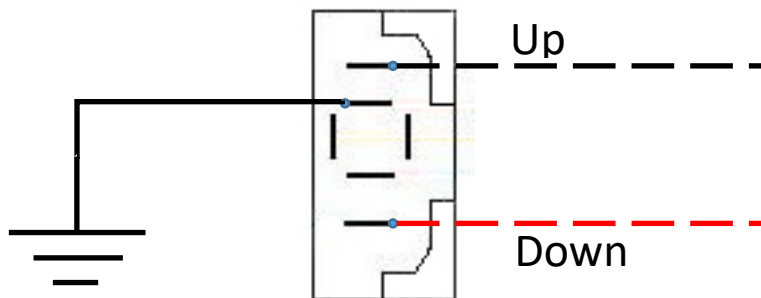

### Checklist for STEP 6: Wiring the Switches

Did you follow the wire colors on the configuration sheet that came with your kit?

Did you make sure that your switches are wired so that no battery voltage can be applied to the ground switched inputs?

Do you have a good connection for the ground side of your switches either using one of the black wires in the CAN and Input harness or a metal-to-metal connection to the chassis?

## Warranty Information

Infinitybox, LLC (“Infinitybox”) warrants against any defects in materials and workmanship to the Product’s INFINITYBOX™ modules, wiring harnesses and accessory modules for a period of one (1) year from the first date of purchase. Subject to the terms of this warranty described below, Infinitybox will replace any such defective Product that is returned to Infinitybox within the one (1) year period from initial purchase. Replacement of any defective part or Product will not extend the applicable warranty period.

The warranty does not apply to: (i) any Product that is not installed in compliance with the applicable Product documentation; (ii) any defect in, or failure of, the Product resulting from an accident, shock, negligence, water immersion or misuse; (iii) any Product that has been modified, adjusted, repaired, or disassembled by any party other than Infinitybox; or (iv) any defect other than in materials and workmanship.

This warranty covers only the original purchaser of Product purchased from an Infinitybox authorized dealer in the United States. In order to receive warranty service, purchaser must provide Infinitybox with a copy of the receipt stating the dealer name, product purchased and date of purchase. Products found to be defective during the warranty period will be replaced (with a product deemed to be equivalent or better) at the discretion of Infinitybox.

Infinitybox’s sole liability for any defective Product is limited solely to the replacement of Product pursuant to this warranty. Infinitybox reserves the right to replace any repairable parts with new or refurbished parts.

INFINITYBOX DISCLAIMS ALL OTHER WARRANTIES, WHETHER EXPRESS, IMPLIED OR STATUTORY, SUCH AS WARRANTIES OF MERCHANTABILITY AND FITNESS FOR PURPOSE. IN NO EVENT SHALL INFINITYBOX BE LIABLE FOR ANY PUNITIVE, INDIRECT, INCIDENTAL OR CONSEQUENTIAL DAMAGES, INCLUDING WITHOUT LIMITATION, LIABILITY FOR LOSS OF USE, LOSS OF PROFITS, LOSS OF PRODUCT OR BUSINESS INTERRUPTION HOWEVER THE SAME MAY BE CAUSED, INCLUDING NEGLIGENCE.



INFINITYBOX, LLC  
6460 West Cortland Street  
Chicago, Illinois 60707  
[www.infinitybox.com](http://www.infinitybox.com)

## Contact Information

The INFINITYBOX™ Intelligent Power Management System

is a product of

**Infinitybox, LLC**  
**6460 West Cortland Street**  
**Chicago, Illinois 60707**

**(847) 232-1991**

**[sales@infinitybox.com](mailto:sales@infinitybox.com)**  
**[www.infinitybox.com](http://www.infinitybox.com)**