

Infinitybox inVIEW Windshield Wiper Control Module
Coast-to-Park Variant
Part Number 852-799-CTP
User Manual

Table of Contents

Overview..... 2
Warnings..... 3
Technical Details 4
inVIEW Wiper Control Module Dimensions..... 5
What’s in the Box? 5
Installation Steps..... 6
Controlling inVIEW 9
Wiper Operation 11
Power-Up and LED Indicators 13
Troubleshooting 14
Warranty Information 15

Overview

The Infinitybox inVIEW Wiper Control Module is a relay-based control module that operates a two-speed automotive windshield wiper motor and a washer pump. It manages all wiper functions — low speed, high speed, intermittent wiping, and washer — internally, so you do not need separate relays, timers, or intermittent-wipe modules in your wiring.

This manual covers the 852-799-CTP variant. The CTP variant is designed for Coast-to-Park wiper motors — motors that use an internal cam switch and a separate park terminal to return the wiper arms to their resting position. When the wipers are switched off, the module continues to power the motor's park terminal, and the motor's internal cam switch drives the arms home and stops them at the park position.

If your motor instead parks by dynamic braking (its brushes are shorted to ground at the park position rather than being driven home), you need the 852-799-DYN variant instead. Check your motor type to confirm you are using the correct inVIEW. If you are not sure whether your wiper system uses a Coast-to-Park or Dynamic Park motor, refer to the literature that came with your wiper system, or contact the wiper system manufacturer.

inVIEW can be controlled three different ways. You can choose whichever fits your build:

- As a stand-alone module with your own switches. Wire any switches you like to the module's four control inputs to operate the low, high, intermittent, and washer functions directly. No CAN network or other electronics are required.
- As a stand-alone module on a J1939 CAN network. Connect any J1939-compatible controller to the module's CAN connection and command the wiper and washer functions over CAN. This manual provides the control messages for the default 250 kb/s setup.
- As part of an Infinitybox system. Connect inVIEW to the CAN network of a compatible Infinitybox system and control the wipers from MASTERCELL switch inputs, inTOUCH screens on inLINK NGX, or the inCONTROL knob. This requires the Infinitybox Next Generation System with the IPM1 kit; the Legacy System does not support CAN control of inVIEW.

Choose a single control method for your installation. Use either your own switches or a CAN source to control inVIEW, but not both at the same time. A CAN controller typically sends its commands repeatedly, and because the module always acts on the most recent command it receives, CAN commands will override anything set by the switches. Each control method is described in detail later in this manual.

Warnings

THE INFINITYBOX inVIEW WIPER CONTROL MODULE CONTROLS A MECHANISM THAT MOVES. THE WIPER ARMS AND LINKAGE CAN START MOVING AT ANY TIME WHEN THE MODULE IS POWERED. KEEP HANDS, TOOLS, AND CLOTHING CLEAR OF THE WIPER ARMS AND LINKAGE DURING INSTALLATION AND TESTING. CARELESS OPERATION CAN DAMAGE YOUR VEHICLE OR CAUSE PERSONAL INJURY.

THE INFINITYBOX inVIEW WIPER CONTROL MODULE IS DESIGNED FOR USE IN VEHICLE ELECTRICAL SYSTEMS. PROPER CARE MUST BE TAKEN TO ENSURE CORRECT WIRING AND TERMINATION OF ALL CONNECTIONS. IMPROPER INSTALLATION CAN CAUSE FAULTY OPERATION OR DAMAGE TO CONNECTED DEVICES.

PROPER CARE MUST BE TAKEN TO ENSURE THAT POWER IS CORRECTLY APPLIED TO THE MODULE. REVERSING POLARITY TO THE POWER AND GROUND FEEDS WILL CAUSE IRREPARABLE DAMAGE TO THE MODULE AND WILL VOID THE WARRANTY.

THE RELAY OUTPUTS ARE DESIGNED TO SWITCH BATTERY POSITIVE TO THE WIPER MOTOR AND WASHER PUMP. DO NOT EXCEED THE RATED CURRENT PER RELAY OR THE RATED CURRENT FOR THE MODULE. EXCEEDING THE CURRENT RATING WILL DAMAGE THE MODULE.

THE WIPER MOTOR'S PARK TERMINAL MUST BE WIRED TO THE PARK OUTPUT OF THIS MODULE FOR THE WIPERS TO RETURN TO THE HOME POSITION CORRECTLY. WIRING THE PARK TERMINAL DIRECTLY TO BATTERY OR LEAVING IT UNCONNECTED WILL DEFEAT THE PARK BEHAVIOR.

IF YOU CONNECT inVIEW TO A CAN NETWORK, THE CAN BUS MUST BE PROPERLY TERMINATED WITH 120Ω RESISTORS AT EACH END OF THE BUS. MISSING OR INCORRECT TERMINATION WILL CAUSE COMMUNICATION ERRORS AND MAY PREVENT THE MODULE FROM COMMUNICATING.

ADDING ANY ELECTRONICS MODULE TO A VEHICLE WILL INCREASE THE DEMAND ON THE BATTERY. CARE MUST BE TAKEN TO MAINTAIN A CHARGE ON THE BATTERY WHEN THE VEHICLE SITS IDLE FOR PERIODS OF TIME.

Technical Details

inVIEW Wiper Control Module Technical Details

| Parameter | Value |
|--------------------------------|--|
| Dimensions | 135 mm × 119 mm × 36 mm / 5.3" × 4.7" × 1.4" |
| Connector Family | Deutsch / TE DTM-06 |
| Min. Operating Voltage | 10 VDC |
| Max. Operating Voltage | 20 VDC |
| Maximum Current Draw Per Relay | 8 Amps |
| Steady-State Current Draw | 0.03 A Nominal |
| Operating Temperature Range | -40°C to +85°C |
| Enclosure Rating | Sealed to IP67 |
| CAN Bus Compatibility | J1939 at 250 kb/s |

inVIEW Wiper Control Module Part Number

| Part Number | Description |
|-------------|--|
| 852-799-CTP | Infinitybox inVIEW Wiper Control Module, Coast-to-Park |

inVIEW Wiper Control Module Dimensions

Dimensions in millimeters

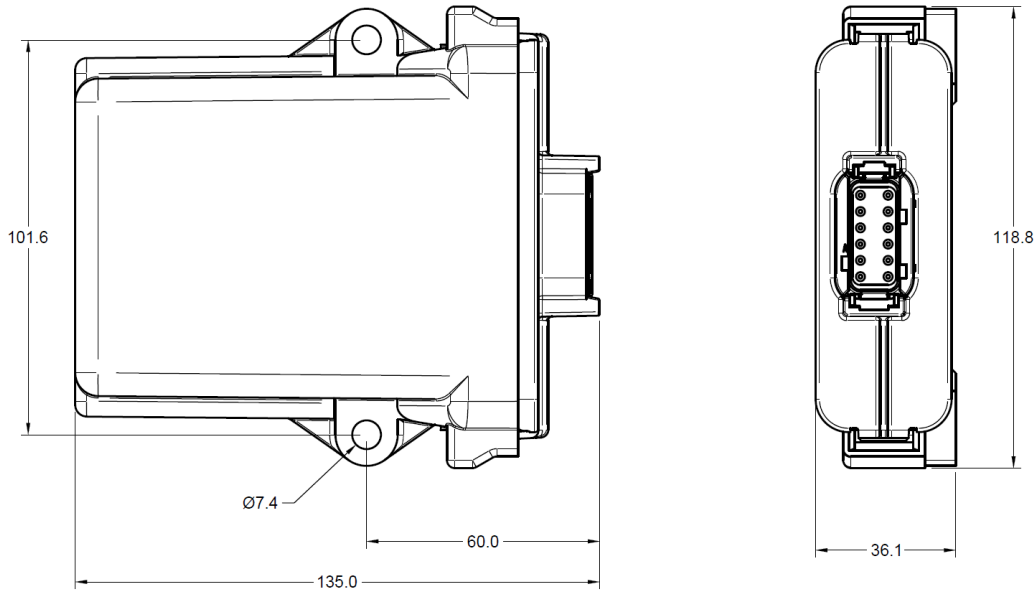

What's in the Box?

Your 852-799-CTP kit contains the following items:

- inVIEW Wiper Control Module (852-799-CTP)
- Wiring harness
- Wedge lock connector retainer
- In-line Mini Fuse holder with 15-amp Mini Fuse

The harness plugs into the inVIEW module and provides a pigtail with leads for power, ground, the wiper motor, and the washer pump, along with the wired switch inputs and the CAN connection. The wired switch inputs and CAN wires are included on the harness whether or not you choose to use them.

The wedge lock retainer is shipped separately and is not installed in the harness connector. This lets you remove any wired switch inputs or CAN wires you are not using before locking the remaining wires in place. The wedge lock is installed during the connector wiring step described in the Installation section.

Installation Steps

Mounting the inVIEW Module

The inVIEW Module can be mounted in any orientation using the provided mounting holes. Select a location that is protected from direct exposure to water spray and excessive heat sources. The enclosure is sealed to IP67 but should not be submerged.

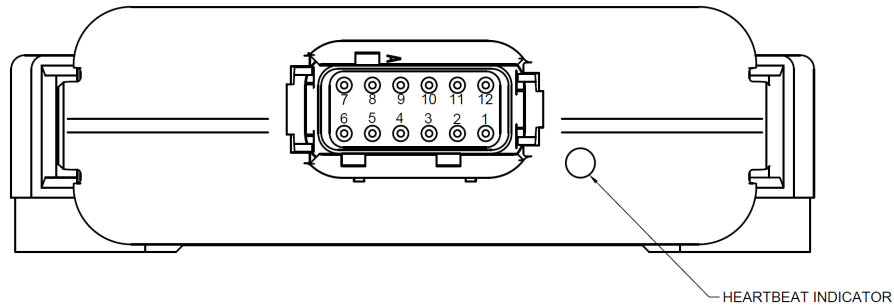

inVIEW Module Connector Details

- Mating connector: DTM-06-12S
- Mating Terminals
 - 1062-20-0222- 16 to 22 AWG
 - 1062-20-0622- 14 to 16 AWG
- Wedge Lock: WM-12S

The harness wires are identified by cavity number and wire color as follows:

| Cavity | Function | Wire Color | Gauge |
|--------|-------------------------------------|-----------------------|--------|
| 1 | CAN LO | Green | 22 AWG |
| 2 | CAN HI | Yellow | 22 AWG |
| 3 | Washer Pump Switch Input | White / Yellow tracer | 22 AWG |
| 4 | Intermittent Switch Input | White / Blue tracer | 22 AWG |
| 5 | Low-Speed Switch Input | White / Black tracer | 22 AWG |
| 6 | Ground | Black | 16 AWG |
| 7 | +Battery or Switched Ignition Power | Red | 16 AWG |
| 8 | High-Speed Switch Input | White / Red tracer | 22 AWG |
| 9 | Low-Speed Output to Wiper Motor | Yellow | 16 AWG |
| 10 | High-Speed Output to Wiper Motor | White | 16 AWG |
| 11 | Park Output to Wiper Motor | Blue | 16 AWG |
| 12 | Washer Pump Output | Brown | 16 AWG |

Supplying Power

The inVIEW module needs battery voltage and ground. Connect the Red wire (cavity 7) to a switched-ignition power source and install the included Mini Fuse holder in-line. If you are powering this from the Ignition output from the POWERCELL NGX in your Infinitybox IPM1 kit, you can use the Ignition fuse and not install the in-line fuse holder. Connect the Black wire (cavity 6) to chassis ground.

Connecting the Wiper Motor

The 852-799-CTP module is designed to drive a two-speed Coast-to-Park wiper motor with a cam-switched park terminal. The wiper motor has three power inputs that connect to three of the module's outputs:

- Low-Speed Output (Yellow, cavity 9): connect to the wiper motor's low-speed power terminal.
- High-Speed Output (White, cavity 10): connect to the wiper motor's high-speed power terminal.
- Park Output (Blue, cavity 11): connect to the wiper motor's park terminal. This terminal must be connected for the wipers to return to the park position correctly.

Verify the wiper motor has a solid ground connection to the vehicle chassis.

Connecting the Washer Pump

Connect the Washer Pump Output (Brown, cavity 12) to the washer pump's positive lead. The washer pump's negative lead connects to chassis ground.

Wiring the Switch Inputs

The four switch inputs — Low-Speed (cavity 5), High-Speed (cavity 8), Intermittent (cavity 4), and Washer (cavity 3) — are ground-switched inputs with internal pull-up resistors. To request a function, the corresponding input wire must be connected to chassis ground; releasing the connection returns the input to its inactive state.

Any single-pole switch may be used. Common configurations include:

- An OEM column-stalk wiper switch with separate output wires for low, high, intermittent, and washer.
- Individual rocker or toggle switches on a custom dash panel, each connected between its input wire and chassis ground.
- A multi-position rotary switch with a common ground terminal.

The Low-Speed, High-Speed, and Intermittent inputs are maintained — the switch holds the input grounded for as long as the function is desired. The Washer input is momentary — the washer pump and wipers run only while the Washer input is held to ground.

The switch inputs can be left disconnected if the module will be controlled exclusively by CAN.

Connecting to CAN Network

Connect the CAN HI (Yellow, cavity 2) and CAN LO (Green, cavity 1) wires to your CAN network. Ensure the network is properly terminated with 120Ω resistors at each physical end of the bus.

If you are using only the discrete switch inputs and not a CAN network, the CAN HI and CAN LO wires can be left disconnected. The module will still operate correctly, although it will report a CAN error on its LED. See the Power-Up and LED Indicators section.

Installing the Wedge Lock

The harness connector is shipped with the WM-12S wedge lock not installed, so you can remove any wires you are not using before locking the connector. Once all your wiring connections are made and you have removed any unused switch-input or CAN wires:

1. Confirm that each terminal is fully seated in its connector cavity.
2. Snap the wedge lock into the front of the connector until it is fully seated.

The illustration below shows how to insert the wedge lock into the connector. The wedge lock locks the terminals in place and should be installed before final operation so that the terminals cannot back out of the connector.

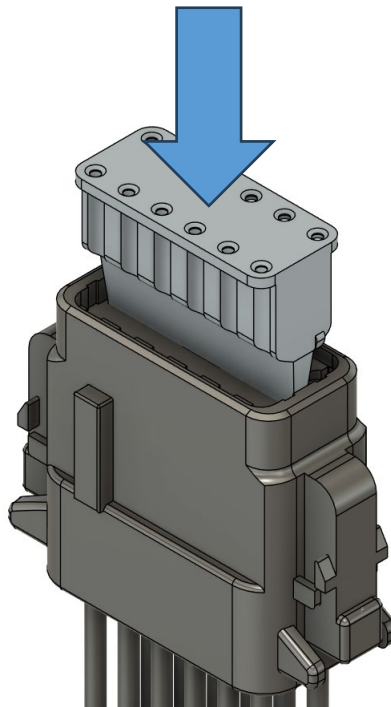

Controlling inVIEW

inVIEW can be controlled three different ways: with your own switches, from a J1939 CAN device, or as part of an Infinitybox Next Generation System. The wiper and washer functions behave the same regardless of how they are commanded; this section covers how to send commands, and the Wiper Operation section describes how the module responds.

Control with Your Own Switches

In the simplest installation, you wire your own switches to the four control inputs — Low-Speed, High-Speed, Intermittent, and Washer — and command the wiper and washer functions directly. No CAN network or other electronics are required. Wiring for the switch inputs is covered in the Installation section.

Control from a J1939 CAN Device

You can command inVIEW from any J1939-compatible device by sending it a control message over CAN. The module ships configured for a 250 kb/s CAN bus using the default message identifiers below.

Default Message Identifiers

| Function | CAN ID | Direction |
|---------------|------------|-------------|
| Control Input | 0x0CFF0D80 | To inVIEW |
| Heartbeat | 0x0CFF4D80 | From inVIEW |

Control Message

Send the control message to CAN ID 0x0CFF0D80 with 8 data bytes. The module identifies this message by its PGN (parameter group number) and accepts it regardless of the source address of the device sending it, so you do not need to set your device to a specific source address. Only the first three data bytes carry commands:

| Byte | Function | Description |
|------|--------------|--|
| 0 | Speed | 0x80 = Low, 0x08 = High |
| 1 | Washer | 0x80 = Wash |
| 2 | Intermittent | 0x80 = On; lower nibble = OFF time in seconds (2-15) |
| 3-7 | Unused | Set to 0x00 |

If more than one speed is requested at once, the module uses the highest: High over Low, Low over Intermittent. If a speed is set in byte 0, the intermittent setting in byte 2 is ignored.

Control Examples

Low only — Data: 80 00 00 00 00 00 00 00

High only — Data: 08 00 00 00 00 00 00 00

Washer (from off, also runs High) — Data: 00 80 00 00 00 00 00 00

Intermittent, 4 s off — Data: 00 00 84 00 00 00 00 00

Intermittent, 8 s off — Data: 00 00 88 00 00 00 00 00

All off — Data: 00 00 00 00 00 00 00 00

Confirming a Command (Heartbeat)

inVIEW transmits a heartbeat message on CAN ID 0x0CFF4D80 once per second, and again immediately each time it receives a control message. You can watch the heartbeat to confirm which functions are on. Two bytes tell you what the module is doing:

| Byte | Reports | Bit Meaning (1 = on) |
|------|---------------|--|
| 6 | Outputs | 0x80 = Low, 0x08 = High, 0x04 = Washer |
| 7 | Switch inputs | 0x80 = Low, 0x08 = High, 0x40 = Int, 0x04 = Wash |

For example, after commanding Low speed, byte 6 of the heartbeat will show bit 0x80 set, confirming the Low output is on.

Advanced Features

inVIEW supports additional advanced features, including reconfiguring its CAN identifiers and adjusting stored settings. For information on these features, contact the Infinitybox technical support group.

Control from an Infinitybox NGX System

inVIEW can be connected to the CAN network of an Infinitybox system and controlled alongside the rest of your vehicle's electrical system. This requires the Infinitybox Next Generation System with the IPM1 kit. The Legacy System does not support CAN control of inVIEW.

When connected to a compatible system, you control the wiper and washer functions over CAN. The commands can come from switches wired to MASTERCELL inputs, from buttons on the inTOUCH screens or from the inCONTROL knob. In each case the Infinitybox system sends the command to inVIEW as a CAN message; this is CAN control, not a connection to inVIEW's own switch inputs.

It is important to understand the difference between the two kinds of switches. The switch inputs on the inVIEW harness (Low-Speed, High-Speed, Intermittent, and Washer) connect

switches directly to the inVIEW module. Switches wired to MASTERCELL inputs are different: they tell the Infinitybox system what you want, and the system then sends a CAN command to inVIEW. Because an Infinitybox system controls inVIEW over CAN, do not also wire switches to the inVIEW harness switch inputs when inVIEW is part of an Infinitybox system. Use one or the other.

MASTERCELL inputs are assigned using inCODE NGX. inTOUCH screen buttons are defined through the inLINK NGX setup process. Refer to those products' documentation for setup details.

Wiper Operation

This section describes how the module behaves in each of its operating modes. The behavior is the same whether the command comes from a switch input, a CAN device, or an Infinitybox system.

Low Speed

When Low speed is requested, the wiper motor runs continuously at low speed. When the request is removed, the motor returns to the park position. The module continues to power the motor's park terminal, and the motor's internal cam switch carries the wiper arms home and stops them at the park position.

High Speed

When High speed is requested, the wiper motor runs continuously at high speed. When the request is removed, the wiper arms return to the park position in the same way as in low speed.

Switching Between Speeds

When changing between low and high speed in either direction, the module inserts a brief pause during which the motor is momentarily off before the new speed engages. This ensures clean switching between the motor's speed connections and is normal operation.

Intermittent

In intermittent mode, the wipers make a single sweep, pause, and repeat. Each cycle begins with a one-second wipe so you get immediate feedback that the function is active, followed by a pause, then the next wipe.

From the factory, the pause between sweeps is set to 4 seconds. This timing can be adjusted; contact the Infinitybox technical support group for details.

Washer

The washer behaves differently depending on whether the wipers are already running when the wash is requested.

Washer With Wipers Off

When the washer is requested while the wipers are off, the pump sprays for one second first to wet the windshield, then the wipers begin running on high speed. The pump and

wipers continue for as long as the request is held. When the request is released, the pump stops, but the wipers continue running on high for an additional 3 seconds to clear residual fluid before returning to park.

Washer With Wipers Already Running

When the washer is requested while the wipers are already running on low or high, the pump runs while the request is held. The wiper speed does not change, and there is no 3-second tail when the request ends.

If the washer is requested during intermittent operation, the pump sprays for one second first, then the wipers run continuously for the duration of the wash so that fluid is not sprayed while the wipers are paused. When the request is released, intermittent cycling resumes.

Washer Behavior Summary

| Wipers When Washer Starts | While Washer Is Held | When Washer Is Released |
|----------------------------------|---|--|
| Off | Pump sprays 1 s, then pump and high-speed run | Pump stops; high continues 3 s, then parks |
| Low | Pump runs; low unchanged | Pump stops; low continues |
| High | Pump runs; high unchanged | Pump stops; high continues |
| Intermittent | Pump sprays 1 s, then pump runs and wipers run continuously | Pump stops; intermittent resumes |

Power-Up and LED Indicators

Normal Power-Up Sequence

When power is applied, the inVIEW module performs a brief startup sequence. The status LED turns on for about one second to confirm the module has powered up, and then the module begins normal operation. The very first time the module is powered, or after a factory reset, the LED also gives two short blinks before the startup indicator to show that it has loaded its factory settings.

If any switch input is held closed at power-up — for example, the Low-Speed switch — the module honors that request as soon as it finishes starting, and the wipers begin operating immediately. Once startup is complete, the LED settles into its normal once-per-second blink.

LED Indicators

| LED Pattern | Meaning |
|--------------------------------------|--|
| One second on at power-up | The module has powered up and is starting. |
| Two short blinks at power-up | Factory settings were loaded. Normal on first power-up or after a factory reset. |
| One blink per second | Normal operation. The module is running and, if connected, the CAN network is healthy. |
| A quick flash on each command | A command was received over CAN and accepted. |
| Three blinks per second | A CAN communication error is present. Expected if the module is not connected to a CAN network; otherwise, check the CAN wiring and termination. |

Troubleshooting

The table below covers the most common issues and how to resolve them. Most problems trace back to a wiring connection. Before testing, make sure the module has power and a good ground, and that all terminals are fully seated in the connector.

| Symptom | Possible Cause | What to Do |
|--|--|---|
| Module is dead; LED never lights | No power or ground, blown fuse, or reversed polarity | Check the fuse, confirm it has battery voltage, and confirm the black wire has a good chassis ground. Verify power and ground are not reversed. |
| Wipers do not respond to a switch | Switch not grounding the input, wrong wire, or the wire was removed from the connector | Confirm the switch connects the correct input wire to chassis ground when pressed, and that the wire is present and seated in the connector. |
| Wipers run but do not return to park; they stop mid-sweep | Park output not connected to the motor's park terminal | Connect the Park output (blue, cavity 11) to the wiper motor's park terminal. This connection is required for the wipers to park. |
| Only one speed works | Low or high output miswired, or poor motor ground | Verify the Low output (yellow, cavity 9) and High output (white, cavity 10) go to the matching motor terminals, and that the motor is well grounded. |
| Washer pump does not run | Pump output or pump ground not connected | Confirm the Washer output (brown, cavity 12) goes to the pump's positive lead and that the pump's other lead is grounded. |
| Wipers run on high when only the washer is pressed | Normal operation | This is expected. When the washer is used with the wipers off, the wipers run on high to clear the windshield. See the Wiper Operation section. |
| Wipers started by themselves at power-up | A switch input was grounded when power was applied | The module honors any switch held at power-up. Check for a stuck switch or a switch wire shorted to ground. |
| LED blinks three times per second | CAN communication error | Expected if the module is not connected to a CAN network and can be ignored. If you are using CAN, check the wiring and termination. |
| No response to CAN commands | Wrong bus speed, missing termination, or CAN HI/LO swapped | Confirm the bus is running at 250 kb/s and terminated with 120Ω at each end, and that CAN HI (yellow, cavity 2) and CAN LO (green, cavity 1) are not swapped. |

If you have worked through the relevant items above and the module still does not operate correctly, contact the Infinitybox technical support group at (847) 232-1991.

Warranty Information

Infinitybox, LLC ("Infinitybox") warrants against any defects in materials and workmanship to the Product's modules, wiring harnesses and accessory modules for a period of one (1) year from the first date of purchase. Subject to the terms of this warranty described below, Infinitybox will replace any such defective Product that is returned to Infinitybox within the one (1) year period from initial purchase. Replacement of any defective part or Product will not extend the applicable warranty period.

The warranty does not apply to: (i) any Product that is not installed in compliance with the applicable Product documentation; (ii) any defect in, or failure of, the Product resulting from an accident, shock, negligence, water immersion or misuse; (iii) any Product that has been modified, adjusted, repaired, or disassembled by any party other than Infinitybox; or (iv) any defect other than in materials and workmanship.

This warranty covers only the original purchaser of Product purchased from an Infinitybox authorized dealer in the United States. In order to receive warranty service, purchaser must provide Infinitybox with a copy of the receipt stating the dealer name, product purchased and date of purchase. Products found to be defective during the warranty period will be replaced (with a product deemed to be equivalent or better) at the discretion of Infinitybox.

Infinitybox's sole liability for any defective Product is limited solely to the replacement of Product pursuant to this warranty. Infinitybox reserves the right to replace any repairable parts with new or refurbished parts.

INFINITYBOX DISCLAIMS ALL OTHER WARRANTIES, WHETHER EXPRESS, IMPLIED OR STATUTORY, SUCH AS WARRANTIES OF MERCHANTABILITY AND FITNESS FOR PURPOSE. IN NO EVENT SHALL INFINITYBOX BE LIABLE FOR ANY PUNITIVE, INDIRECT, INCIDENTAL OR CONSEQUENTIAL DAMAGES, INCLUDING WITHOUT LIMITATION, LIABILITY FOR LOSS OF USE, LOSS OF PROFITS, LOSS OF PRODUCT OR BUSINESS INTERRUPTION HOWEVER THE SAME MAY BE CAUSED, INCLUDING NEGLIGENCE.